

# Leyland 245 - 262 - 272 - 462 - 472 'Q' Cab Tractor - Electrical Wiring Diagram

## WIRING DIAGRAM

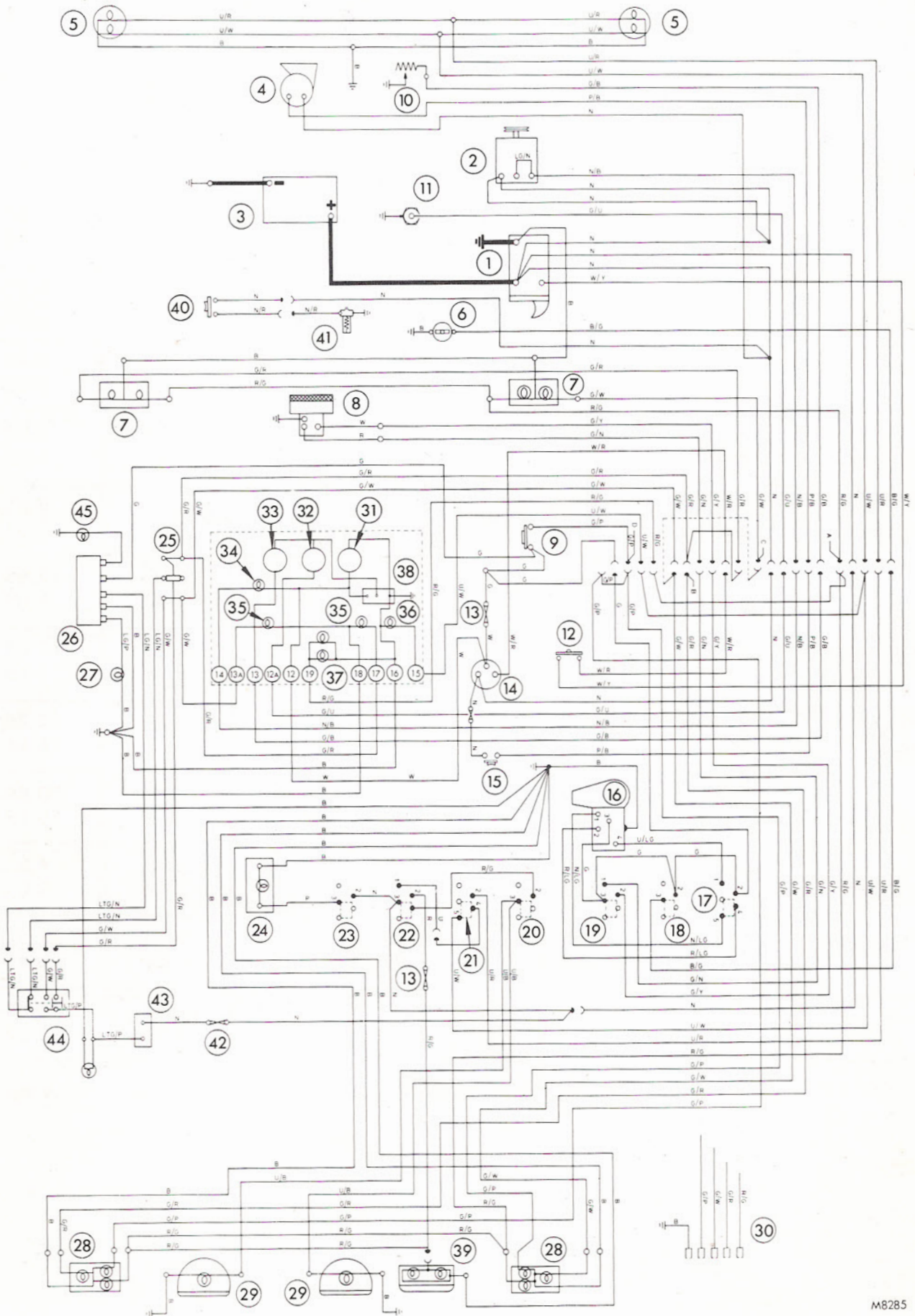

## KEY TO WIRING DIAGRAM - 245 - 262 - 272 - 462 - 472 'Q' CAB MODELS

<i>No.</i>	<i>Description</i>	<i>No.</i>	<i>Description</i>
1.	Starter motor	24.	Interior light
2.	Alternator	25.	Direction indicator (flasher) switch
3.	Battery	26.	Flasher unit
4.	Horn	27.	Trailer flasher warning light
5.	Headlight	28.	Tail / flasher / stop light combined
6.	Washer pump	29.	Plough light
7.	Side / flasher light combined	30.	Trailer socket
8.	Heater	31.	Battery condition indicator
9.	Stop light switch	32.	Temperature gauge
10.	Fuel tank unit	33.	Fuel gauge
11.	Temperature transmitter	34.	No-charge warning light
12.	Safety start switch	35.	Flasher warning light
13.	Line fuse X - 25 Amp Y - 10 Amp	36.	Main beam warning light
14.	Master / starter switch	37.	Instrument panel lights
15.	Horn push	38.	Voltage stabilizer
16.	Wiper motor	39.	Number plate light (if fitted)
17.	Wiper switch	40.	Heater plug ('Thermostart') switch (if fitted)
18..	Washer switch	41.	'Thermostart' (if fitted)
19.	Heater switch	42.	Hazard flasher unit fuse
20.	Plough lamp switch	43.	Hazard light unit
21.	Main beam / dip switch	44.	Hazard light switch
22.	Side / headlight switch	45.	Trailer warning light
23.	Interior light switch		

### CABLE COLOUR CODE

B.	Black	Y.	Yellow	LG.	Light green
N.	Brown	U.	Blue	P.	Purple
R.	Red	G.	Green	W.	White

When a cable has two colour code letters the first denotes the main colour and the second denotes the tracer colour